

The Lighthill-Whitham-Richards and the Associated Dirichlet Problem With Inequality Constraints for the Hamilton-Jacobi Equation

Jean-Pierre Aubin, Alexandre Bayen et Patrick Saint-Pierre

Conférence Internationale  
sur les Mathématiques de l'Optimisation et de la Décision 2006

Université des Antilles-Guyanne  
Guadeloupe

Le 20 avril 2006



# 1 Introduction

In the case when  $K := [\xi, +\infty[$  represents a road and the function  $\psi$  is concave, the solution  $\mathbf{V}(t, x)$  to the **Lighthill-Whitham-Richards** partial differential equation

$$\frac{\partial \mathbf{V}(t, x)}{\partial t} + \frac{\partial \psi(\mathbf{V}(t, x))}{\partial x} = 0$$

models the **density**  $\mathbf{V}(t, x)$  of the traffic and its primitive  $\mathbf{N}(t, x) = \int_{\xi}^x \mathbf{V}(t, u) du$  is a solution to the Dirichlet/initial value-problem for a **Hamilton-Jacobi** equation

$$\frac{\partial \mathbf{N}(t, x)}{\partial t} + \psi \left( \frac{\partial \mathbf{N}(t, x)}{\partial x} \right) = \psi(v(t))$$

modelling the **cumulated number**  $\mathbf{N}(t, x)$  of vehicles. Both equations model the same physical phenomenon.

We are furthermore looking for solutions to these equations **obeying inequality constraints**.

We define the graph of the “**viability solution**” to

$$\frac{\partial \mathbf{V}(t, x)}{\partial t} + \frac{\partial \psi(\mathbf{V}(t, x))}{\partial x} = 0$$

and the hypograph of the “**viability solution**” to

$$\frac{\partial \mathbf{N}(t, x)}{\partial t} + \psi \left( \frac{\partial \mathbf{N}(t, x)}{\partial x} \right) = \psi(v(t))$$

as *viaible-capture basins of graphs and hypographs* of maps associated with the initial and Dirichlet conditions under auxiliary system viable in the graphs and hypographs of the constraints.

Translating the properties of capture basins, we obtain corresponding properties of these viability solutions, whereas the Viability and Invariance Theorems imply that they are “generalized solutions” of the partial differential equations, where derivatives are respectively **graphical and hypographical derivatives**.

Being characterized by capture basins, **the Saint-Pierre Capture Basin Algorithm allows us to compute these solutions**.



## Contents

<b>1</b>	<b>Introduction</b>	<b>2</b>
<b>2</b>	<b>The Lighthill-Whitham-Richards Model</b>	<b>5</b>
<b>3</b>	<b>Graphical Derivatives</b>	<b>15</b>
<b>4</b>	<b>Further Properties</b>	<b>17</b>
<b>5</b>	<b>Hamilton-Jacobi Equation</b>	<b>24</b>
<b>6</b>	<b>Generalized Solutions</b>	<b>34</b>

## 2 The Lighthill-Whitham-Richards Model



### Network model

Highway systems can be modeled by a network of interconnected LWR PDEs coupled by boundary conditions

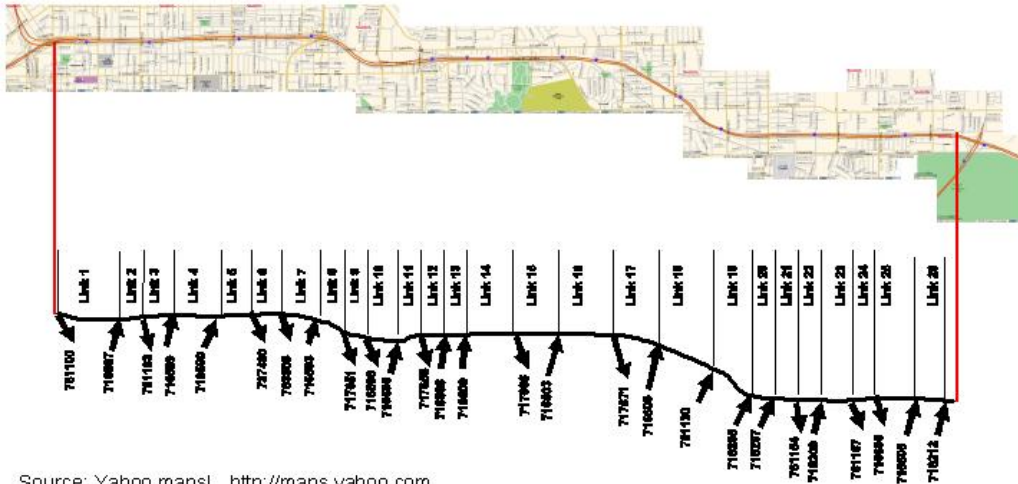

Source: Yahoo maps! <http://maps.yahoo.com>,  
Berkeley PATH, PeMS database

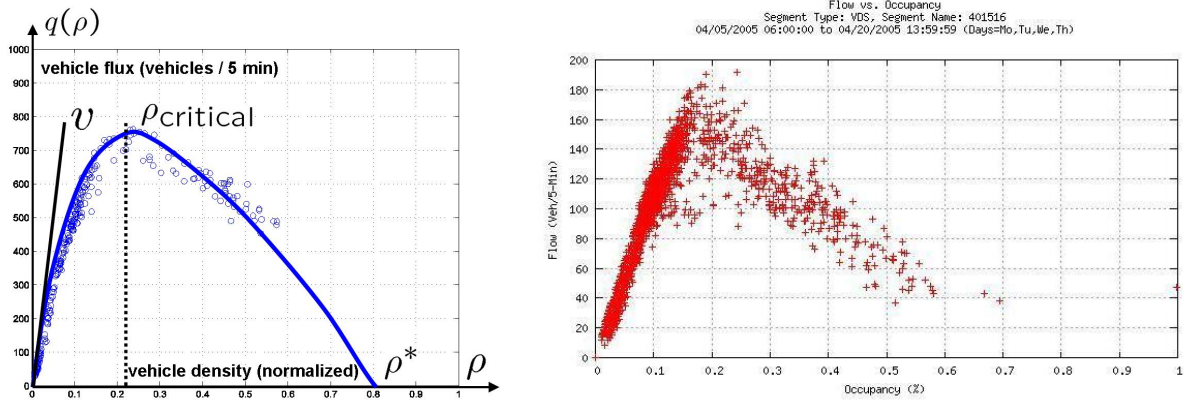

**Figure 1 Empirical Fluxes.** Empirical measurement on interstate I210 in Pasadena of  $\psi(\cdot)$ . Each of the dots is one measurement. The solid curve is a fit of the measurement. As can be seen, for small vehicle densities, the flux function increases linearly with the density (slope  $\nu$ ). It reaches a maximum for a critical density, called  $\gamma$ . For higher densities, it decreases until it finally reaches zero for a density  $\omega$  called jam density.



**1. *Greenshield Flux***

$$\psi(p) = \begin{cases} \nu p & \text{if } p \leq 0 \\ \frac{\nu}{\omega} p(\omega - p) & \text{if } p \in [0, \omega] \\ \nu(\omega - p) & \text{if } p \geq \omega \end{cases}$$

**2. *Daganzo Trapezoidal Flux***

$$\psi(p) = \begin{cases} \nu^b p & \text{if } p \leq \gamma^b \\ \delta & \text{if } p \in [\gamma^b, \gamma^\#] \\ \nu^\#(\omega - p) & \text{if } p \geq \gamma^\# \end{cases}$$



$$\frac{\partial \mathbf{V}}{\partial t} + \frac{\partial \psi(\mathbf{V})}{\partial x} = 0 \quad (1)$$

With the **Greenshield** flux function, we obtain the LWR PDE:

$$\frac{\partial \mathbf{V}}{\partial t} + \frac{\nu}{\omega} \frac{\partial \mathbf{V}}{\partial x} (\omega - \frac{1}{2} \mathbf{V}(x)) = 0 \quad (2)$$

and with the **Daganzo** flux function, the PDE :

$$\left\{ \begin{array}{ll} \frac{\partial \mathbf{V}}{\partial t} + \nu^b \frac{\partial \mathbf{V}}{\partial x} = 0 & \text{if } \frac{\partial \mathbf{V}}{\partial x} \leq \gamma^b \\ \frac{\partial \mathbf{V}}{\partial t} = 0 & \text{if } \frac{\partial \mathbf{V}}{\partial x} \in [\gamma^b, \gamma^\#] \\ \frac{\partial \mathbf{V}}{\partial t} - \nu^\# \frac{\partial \mathbf{V}}{\partial x} = 0 & \text{if } \frac{\partial \mathbf{V}}{\partial x} \geq \gamma^\# \end{array} \right. \quad (3)$$

When  $\psi(y) := \frac{1}{2}y^2$  (convex flux), we obtain the **Burgers' equation**

$$\frac{\partial \mathbf{V}(t, x)}{\partial t} + \frac{\partial \mathbf{V}(t, x)}{\partial x} \mathbf{V}(t, x) = 0 \quad (4)$$



Even when the initial condition  $V_0$  is single-valued, the solution  $V(T, x)$  (given by the characteristic method) may be set-valued for several values of  $T$  and  $x$ . The following cases do appear:

1.  $V(t, x) = \{y\}$  (singleton)
2.  $V(t, x) = \{y_1, \dots, y_p\}$  (finite number of branches)
3.  $V(t, x) = S$  where  $S$  is an interval (**shock**)
4.  $V(t, x) = \emptyset$  (the solution ceases to exist)

These phenomena (shocks, several branches, nonexistence) obtained even for the simplest initial conditions have been observed since Riemann, and have embarrassed physicists (who hate to have set-valued solutions and demand to single out THE single-valued ONE which makes “physical sense”).



However, the solutions to the first-order partial differential equations may be set-valued.

This is not really a problem, since we can differentiate set-valued maps thanks to the concept of *graphical derivatives* of set-valued maps and give a meaning to the above nonlinear partial differential equations.

We will do that even for partial differential inclusions

$$\frac{\partial \mathbf{V}(t, x)}{\partial t} + \frac{\partial}{\partial x} \psi(\mathbf{V}(t, x)) \in G(t, x, \mathbf{V}(t, x))$$

We shall prove that the graph of the solution is a capture basin, and thus inherit its properties.

They can be computed by the Saint-Pierre Viability Kernel Algorithm.



Given initial and boundary conditions:

1. **Existence** (in the Frankowska “set-valued” sense)
2. **Uniqueness** (in the class of set-valued maps with closed graph)
3. **Stability** (Convergence of graphs)
4. *A posteriori* estimates (**Maximum principle**)
5. **Union-linearity**
6. A wonderful **algorithm**

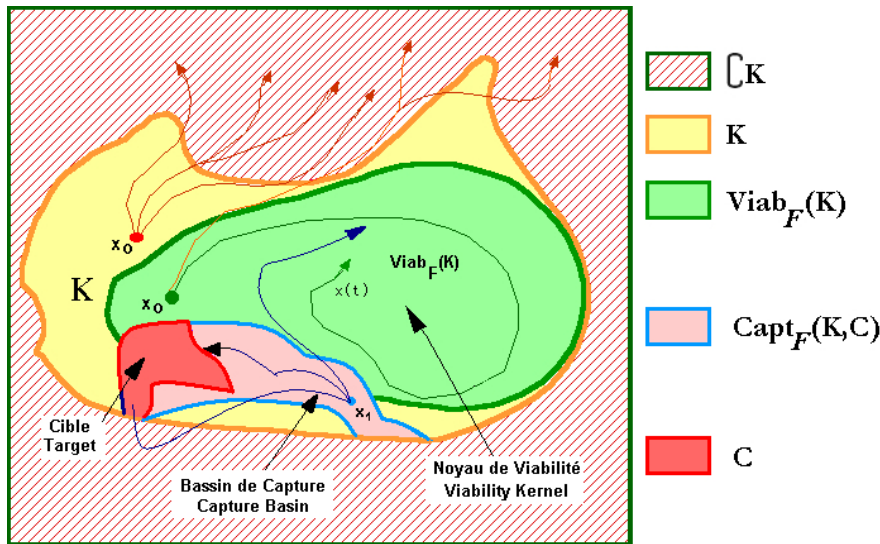

Let  $C \subset K \subset X$  be two subsets,  $C$  being regarded as a target,  $K$  as a constrained environment. The *viable-capture basin*  $Capt(K, C)$  of  $C$  in  $K$  is the set of initial states  $x_0 \in K$  such that  $C$  is reached in **finite time** before possibly leaving  $K$  by at least one solution  $x(\cdot) \in \mathcal{S}(x_0)$  of the control system starting at  $x_0$ .

$$Capt_{\mathcal{S}}(K, C) := \{x \in K \mid \exists x(\cdot) \in \mathcal{S}(x), \exists t^* > 0 \text{ such that } x(t^*) \in C \text{ and } \forall t \in [0, t^*], x(t) \in K\}$$



The “characteristic system” associated with the partial differential equation:

$$\begin{cases} (i) & \tau'(t) = -1 \\ (ii) & x'(t) = -\psi'(y(t)) \\ (iii) & y'(t) = 0 \end{cases} \quad (5)$$

*Greenshield:*

$$\begin{cases} (i) & \tau'(t) = -1 \\ (ii) & x'(t) = -\frac{\nu}{\omega}(\omega - \frac{1}{2}y(t)) \\ (iii) & y'(t) = 0 \end{cases} \quad (6)$$

*Daganzo:*

$$\begin{cases} (i) & \tau'(t) = -1 \\ (ii) & x'(t) = \begin{cases} -\nu^b & \text{if } y(t) \leq \gamma^b \\ 0 & \text{if } y(t) \in [\gamma^b, \gamma^\#] \\ \nu^\# & \text{if } y(t) \geq \gamma^\# \end{cases} \\ (iii) & y'(t) = 0 \end{cases} \quad (7)$$



Let  $K := [\xi, +\infty[$ ,  $\Psi_\xi$  defined by

$$\Psi_\xi(t, x) := \begin{cases} [\underline{y}, \bar{y}] & \text{if } x \geq \xi \\ \emptyset & \text{if } x < \xi \end{cases}$$

$U_0 : X \rightsquigarrow Y$  the initial condition and  $\Gamma_\xi$  the boundary condition at  $\xi$ : We set  $U_0(t, x) := \emptyset$  if  $t > 0$  and  $\Gamma_\xi(t, \xi) := \Gamma_\xi(t)$  and for  $x > \xi$ ,  $\Gamma_\xi(t, x) := \emptyset$ .

**Theorem 2** *The viability solution defined by*

$$\text{Graph}(\mathbf{V}) := \text{Capt}_{(5)}(\text{Graph}(\Psi_\xi), \text{Graph}(\mathbf{V}_0) \cup \text{Graph}(\Gamma_\xi))$$

*is the unique solution in the Frankowska set-valued sense satisfying the initial condition  $\mathbf{V}(0, x) = \mathbf{V}_0(x)$  and the boundary condition  $U(t, \xi) = \Gamma_\xi(t)$ .*



### 3 Graphical Derivatives

Graphical derivatives of set-valued maps were defined in 1981. The graph of *graphical derivative*  $DV(t, x, y)$  from  $\mathbf{R} \times X$  to  $Y$  is equal to the contingent cone to the graph of  $V$  at  $(t, x, y)$ :

$$T_{\text{Graph}(V)}(t, x, y) = \text{Graph}(DV(t, x, y))$$

This is how **Pierre de Fermat** defined in 1637 the derivative of a function as the slope of the tangent to its graph.

Consequently, to say that  $g \in Y$  belongs to the *graphical derivative*  $DV(t, x, y)(\pm 1, f)$  of  $V$  at  $(t, x, y)$  in the direction  $(\pm 1, f) \in \mathbf{R} \times X$  means that

$$\liminf_{h \rightarrow 0+, f' \rightarrow f} \left\| \frac{V(t \pm h, x + hf') - y}{h} - g \right\| = 0$$



Being a capture basin, the graph of the viability solution is characterized by tangential conditions that imply that the viability solution to the conservation law (1) is actually the unique solution (with closed graph) in the Frankowska sense, when the derivatives are meant to be the graphical derivatives of a set-valued map:

**Theorem 3** *The viability solution  $V$  is the **unique Frankowska solution** to the conservation law (1) satisfying the initial condition  $V(0, x) := V_0(x)$  and the boundary condition  $U(t, \xi) = \Gamma_\xi(t)$  in the sense that the graph of  $V$  is closed and satisfies*

$$\begin{cases} \forall t > 0, \forall x > \xi, \forall y \in \mathbf{V}(t, x), 0 \in D\mathbf{V}(t, x, y)(-1, -\psi'(y)) \\ \forall t \geq 0, \forall x \geq \xi, \forall y \in \mathbf{V}(t, x), 0 \in D\mathbf{V}(t, x, y)(1, \psi'(y)) \end{cases}$$



## 4 Further Properties

Furthermore,  $\mathbf{V}(T, x)$  is the set of velocities  $y$  satisfying

$$\begin{cases} y \in \mathbf{V}_0(x - T\psi'(y)) & \text{if } T \leq \frac{x - \xi}{\psi'(y)} \\ y \in \Gamma_\xi\left(T - \frac{x - \xi}{\psi'(y)}, \xi\right) & \text{if } T \geq \frac{x - \xi}{\psi'(y)} \end{cases}$$

It satisfies the “maximum principle”

$$\forall (t, x) \in \mathbb{R}_+ \times K, \quad \mathbf{V}_\xi(t, x) \subset (\text{Im}(\mathbf{V}_0) \cup \text{Im}(\Gamma_\xi)) \cap [y, \bar{y}]$$



We also derive from the stability properties of capture basins that the solution *depends continuously on the initial conditions* for an adequate concept of convergence:

Since the initial conditions and/or the solutions may be set-valued maps, this stability property has a meaning when the *convergence of the set-valued maps is defined by the convergence of their graphs* (graphical convergence).



## *Union Dependence on Initial Conditions*

The capture basin of an union of targets being (obviously) the union of the capture basins of each of the targets, the map associating with any initial/boundary condition  $(V_{0_i}, \Gamma_{\xi, i})$  the solution  $V_i(t, x)$  is a *morphism with respect to the union* (of set-valued maps):

$$\text{if } V_0(x) := \bigcup_{i \in \mathbb{I}} V_{0_i}(x), \Gamma_{\xi}(t) := \bigcup_{i \in \mathbb{I}} \Gamma_{\xi, i}(t), \text{ then } V(t, x) = \bigcup_{i \in \mathbb{I}} V_i(t, x)$$

The solution depends “unionly” on the initial conditions (instead of linearly).

The group structure  $(+, 0)$  of the vector space is replaced by the lattice structure  $(\cup, \emptyset)$  on the subsets of the vector space, for which the maps associating an initial condition the solution of the semi-linear equation is a lattice-morphism.

This morphism property is as useful as the linearity property of solutions to linear systems.

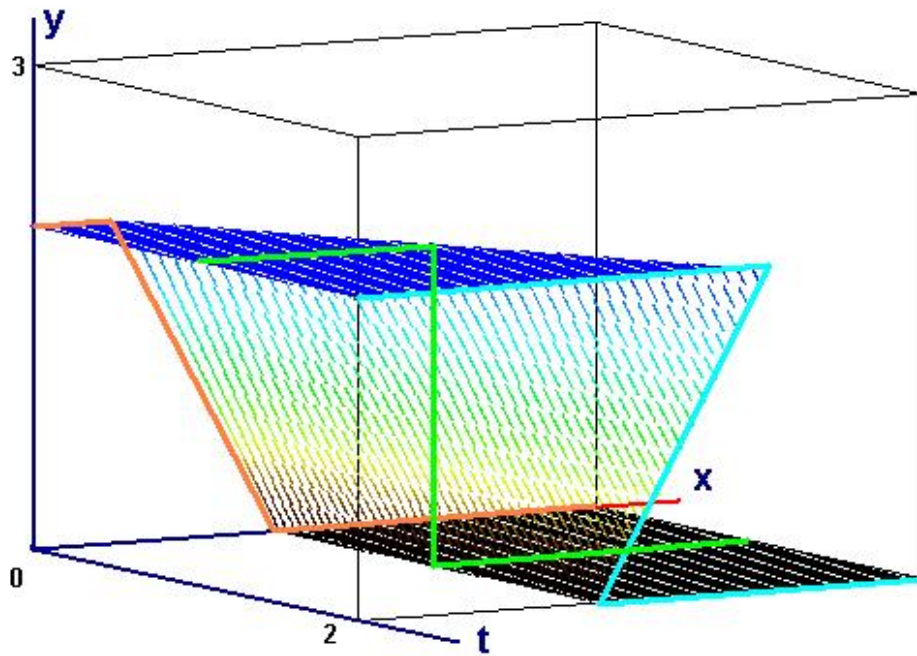

Figure 1: **Initial/Boundary-Value Problem in the case of Constraints on Spatial Variables.** The viability solution is the capture basin of the union of the graph of the initial condition  $\mathbf{V}_0 := 2\Xi([0, 1]; x) \cup 2(2 - x)\Xi([1, 2]; x) \cup 0\Xi([2, 5]; x)$  and of the graph of the boundary condition  $\Gamma_0(t) := 2\Xi([0, 2]; t)$ . See Figure ???. Source: Patrick Saint-Pierre.

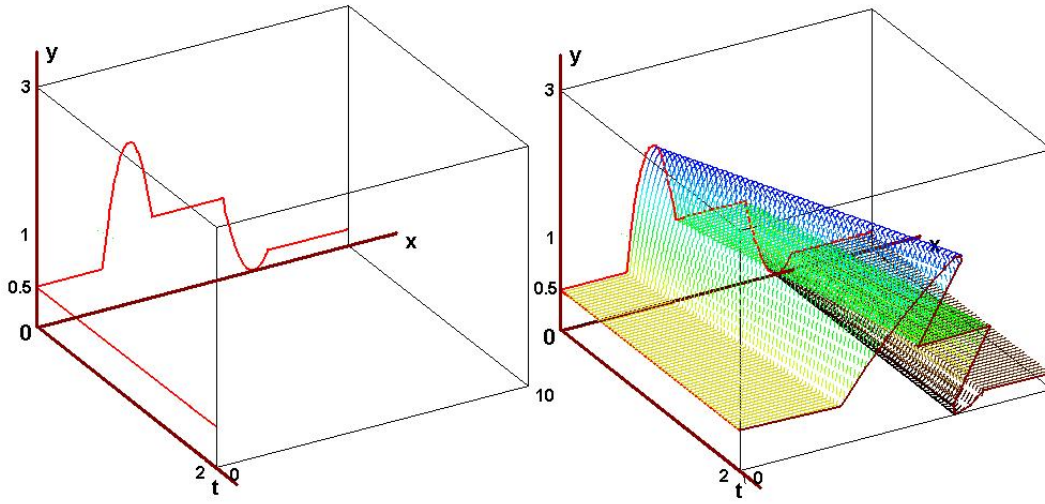
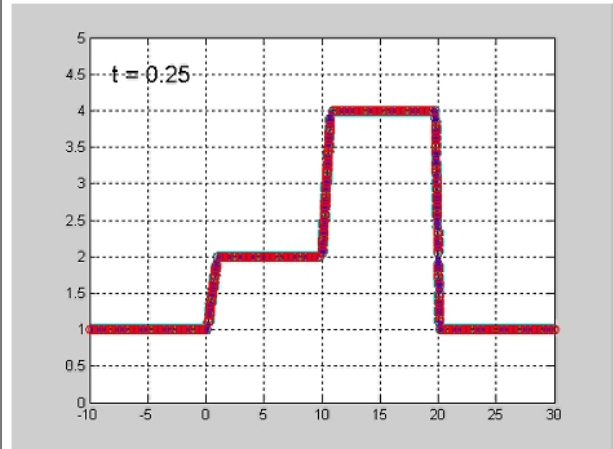
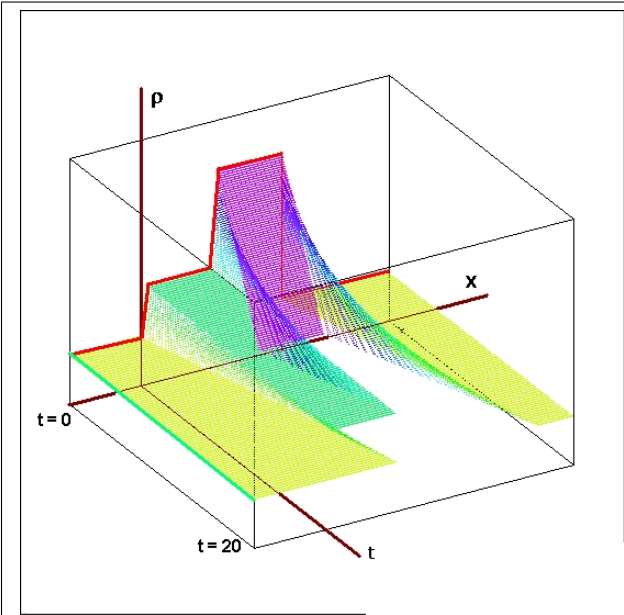
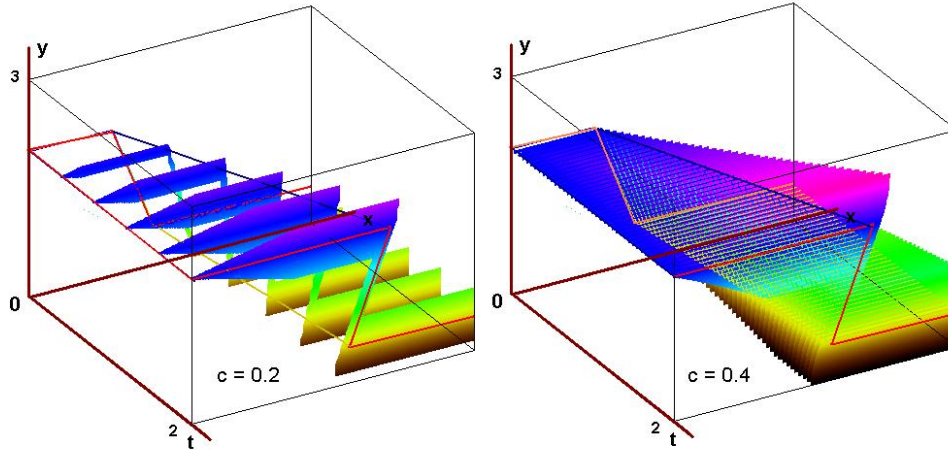

Figure 2: *Example of viability solution to the Burgers' equation with initial data  $\mathbf{V}_0(x) := \max(0.5, 2(1 - (x - 3)^2))\Xi([0, 3]; x) \cup \max(1, 2(1 - (x - 3)^2))\Xi([3, 5]; x) \cup \min(1, (x - 7)^2)\Xi(5, 7[]; x) \cup \max(0.2, (x - 7)^2)\Xi([7, 10]; x)$  and boundary condition  $\Gamma_0(t) := 0.5\Xi([0, 2]; t)$ .*

## Viability solution



- ..... Analytical entropy solution
- Analytical viability solution
- ooo Numerical viability solution



**Figure 4 Viability Solution to the Controlled Burgers' Equation.**

$\frac{\partial \mathbf{V}(t,x)}{\partial t} + \frac{\partial \mathbf{V}(t,x)}{\partial x} \mathbf{V}(t,x) = u$  where  $u \in [-c, +c]$  for 2 values of  $c = 0.2$  &  $0.4$  with initial condition equal to  $\mathbf{V}_0 := 2\Xi([0, 1]; x) \cup 2(2 - x)\Xi([1, 2]; x) \cup 0\Xi([2, 5]; x)$  and boundary condition equal to  $\Gamma_0(t) := \Xi([0, 0.5]; t) \cup 1.5\Xi([1, 2]; t)$ . It still has the familiar Z-shape, but with “thick” values. They are “separated” for  $c = 0.2$  for the sake of clarity.



## 5 Hamilton-Jacobi Equation

Cumulated number of vehicles:

$$\mathbf{N}(t, x) = \int_{\xi}^x \mathbf{V}(t, u) du \quad (8)$$

represents the cumulated number of vehicles between positions  $\xi$  and  $x$ ; Integrating yields

$$\frac{\partial \mathbf{N}(t, x)}{\partial t} + \psi \left( \frac{\partial \mathbf{N}(t, x)}{\partial x} \right) = \psi \left( \frac{\partial \mathbf{N}(t, \xi)}{\partial x} \right) \quad (9)$$

where  $v(t) := \frac{\partial \mathbf{N}(t, \xi)}{\partial x}$  is taken as a control. It satisfies

**Initial condition:**  $\mathbf{N}(0, x) = \mathbf{N}_0(x) := \psi(\mathbf{V}_0(x))$ ,

**Boundary condition:**  $\mathbf{N}(t, \xi) := 0$ .



We shall solve the existence of a solution to the *non-homogenous Hamilton-Jacobi equation*

$$\forall t > 0, x \in \text{Int}(K), \quad \frac{\partial \mathbf{N}(t, x)}{\partial t} + \psi \left( \frac{\partial \mathbf{N}(t, x)}{\partial x} \right) = \psi(v(t)) \quad (10)$$

satisfying the *initial and Dirichlet conditions*

$$\begin{cases} (i) & \forall x \in K, \mathbf{N}(0, x) = \mathbf{N}_0(x) \text{ (initial condition)} \\ (ii) & \forall t \geq 0, \forall \xi \in \partial K, \mathbf{N}(t, \xi) = \gamma(t, \xi) \text{ (Dirichlet boundary condition)} \end{cases} \quad (11)$$

and the *viability constraints*

$$\forall t \geq 0, x \in K, \quad \mathbf{N}(t, x) \leq \mathbf{b}(t, x) \text{ (upper inequality constraint)} \quad (12)$$

1. The flux function  $\psi : X \mapsto \mathbb{R}$  is **concave** and satisfies

$$\forall v \in X, \quad \beta - \sigma_A(v) \leq \psi(v) \leq \delta - \sigma_A(v)$$

for some compact convex subset  $A \subset X$ , where  $\sigma_A(v) := \sup_{u \in A} \langle u, v \rangle$  is the support function of  $A$  and where  $\beta \leq \delta$ ,

2. a **bounded continuous** function  $v : \mathbb{R}_+ \mapsto \text{Dom}(\psi)$
3. an **upper semicontinuous initial datum**  $\mathbf{N}_0 : X \mapsto \mathbb{R}_+$ . We set  $\mathbf{N}_0(0, x) := \mathbf{N}_0(x)$  and  $\mathbf{N}_0(t, x) := -\infty$  if  $t > 0$ .
4. a **closed subset**  $K \subset X$  with **nonempty interior**  $\text{Int}(K) =: \Omega$  and boundary  $\partial K =: \Gamma$ ,
5. an **upper semicontinuous boundary datum**  $\gamma : \mathbb{R}_+ \times X \mapsto \mathbb{R}$ , satisfying

$$\forall t \geq 0, \quad \forall x \in \text{Int}(K), \quad \gamma(t, x) = -\infty$$

6. a **Lipschitz** function  $\mathbf{b} : \mathbb{R}_+ \times X \mapsto \mathbb{R} \cup \{-\infty\}$  setting the upper constraint.

The **Fenchel conjugate**  $\varphi^*$  is defined by  $\varphi^*(u) := \sup_{p \in \text{Dom}(\psi)} [\langle p, u \rangle + \psi(p)]$ . We introduce the auxiliary characteristic control system:

$$\begin{cases} \tau'(t) = -1 \\ x'(t) = u(t) \\ y'(t) = \varphi^*(u(t)) - \psi(v(\tau(t))) \text{ where } u(t) \in \text{Dom}(\varphi^*) \end{cases} \quad (13)$$

We set  $\mathbf{c}(t, x) := \max(\mathbf{N}_0(t, x), \gamma(t, x))$ , defined by

$$\mathbf{c}(t, x) := \begin{cases} -\infty & \text{if } t > 0 \text{ and } x \in \Omega := \text{Int}(K) \\ \mathbf{N}_0(x) & \text{if } t = 0 \text{ and } x \in K \\ \gamma(t, x) & \text{if } t \geq 0 \text{ and } x \in \Gamma := \partial K \end{cases}$$

**Definition 5** *The viability hyposolution  $\mathbf{N}$  is defined by*

$$\mathbf{N}(t, x) := \sup_{(t, x, y) \in \text{Capt}_{(13)}(\mathcal{Hyp}(\mathbf{b}), \mathcal{Hyp}(\mathbf{c}))} y \quad (14)$$

Assume the consistency conditions:

$$\left\{ \begin{array}{l} (i) \quad \forall x \in \partial K, \mathbf{N}_0(x) = \gamma(0, x) \\ (ii) \quad \forall t \geq 0, \forall x \in K, \max(\mathbf{N}_0(t, x), \gamma(t, x)) \leq \mathbf{b}(t, x) \\ (iii) \quad \forall 0 \leq r \leq s, \forall x \in \partial K, \forall y \in \partial K, \gamma(r, x) - \gamma(s, y) \leq \left\langle \frac{1}{s-r} \int_r^s v(\tau) d\tau, x - y \right\rangle \\ (iv) \quad \forall x \in K, \forall y \in \partial K, \mathbf{N}_0(x) \leq \inf_{s \geq 0} \left( \gamma(s, y) + \left\langle \frac{1}{s} \int_0^s v(\tau) d\tau, x - y \right\rangle \right) \end{array} \right. \quad (15)$$

Then the viability hypsolution satisfies the *initial and Dirichlet conditions*

$$\left\{ \begin{array}{l} (i) \quad \forall x \in K, \mathbf{N}(0, x) = \mathbf{N}_0(x) \text{ (initial condition)} \\ (ii) \quad \forall t \geq 0, \forall \xi \in \partial K, \mathbf{N}(t, \xi) = \gamma(t, \xi) \text{ (Dirichlet boundary condition)} \end{array} \right. \quad (16)$$

and the *viability constraints*

$$\forall t \geq 0, x \in K, \mathbf{N}(t, x) \leq \mathbf{b}(t, x) \text{ (upper inequality constraint)} \quad (17)$$

The viability hyposolution  $\mathbf{N}$  defined by (14) is the *largest* upper semicontinuous solution to Hamilton-Jacobi equation (10) satisfying initial and Dirichlet conditions (16) and inequality constraints (17) in both the contingent solution sense (see 20) and in the contingent normal sense (see (23)).

If the functions  $\psi$ ,  $\varphi^*$  and  $v$  are furthermore Lipschitz, then the viability hyposolution  $\mathbf{N}$  is its *unique* upper semicontinuous solution in both the contingent Frankowska sense (see (21 and (22)) and in the Barron-Jensen/Frankowska sense (see (24 and (25))):

$$\forall t > 0, \forall x \in \text{Int}(K) \text{ such that } \mathbf{N}(t, x) < \mathbf{b}(t, x),$$

$$\forall (p_t, p_x) \in \partial_+ \mathbf{N}(t, x), \quad p_t + \psi(p_x) = \psi(v(t))$$

## Computation of the solution

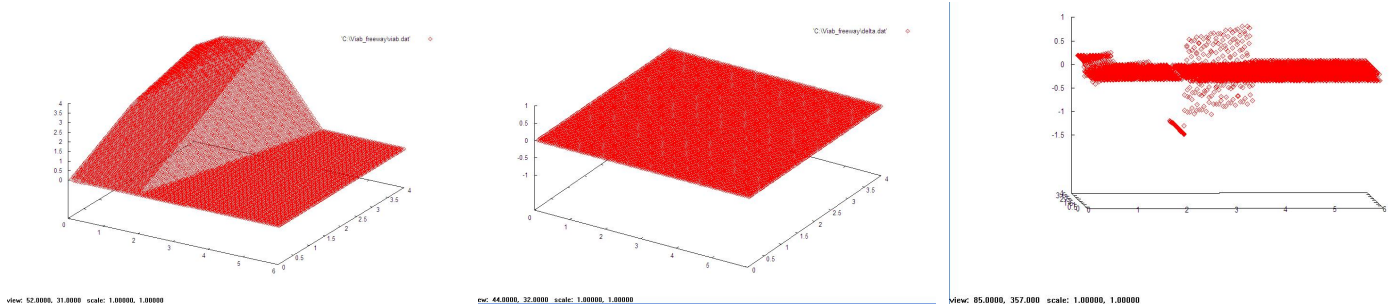

Figure 6 Both the viability kernel and capture basin algorithms are used to provide upper and lower estimates of the solution and thus, to furnish “**a posteriori errors**”. The abscisses represent the variable  $x$ , the ordinates the time variable  $t$  and altitude the value of the solution. The first graphic provides the solution, the second the **a posteriori error** (equal to 0!) and the third one the verification that the solution actually satisfies the equation. Due to the fact that the solution may not be differentiable, the union of the super-gradients is entered in the flux, so that several values (including 0) enter the value the equation at such points of non differentiability. Source: Christian Claudel.

The Fenchel conjugate  $\varphi^*$  is defined by  $\varphi^*(u) := \sup_{p \in \text{Dom}(\psi)} [\langle p, u \rangle + \psi(p)]$ . Set  $\tau(x, u) = \inf_{x+tu \notin K} t$ . In the absence of constraints, the viability hyposolution (18), p.31 can be written

$$\mathbf{N}(t, x) = \max(\mathbf{N}_{N_0}(t, x), \mathbf{N}_\gamma(t, x))$$

where

$$\left\{ \begin{array}{l} \mathbf{N}_{N_0}(t, x) = \sup_u (\mathbf{N}_0(x + tu) - t\varphi^*(u)) + \int_0^t \psi(v(\tau))d\tau \\ \mathbf{N}_\gamma(t, x) = \sup_{\{u \in \text{Dom}(\varphi^*) | \tau(x, u) \leq t\}} (\gamma(t - \tau(x, u), x + \tau(x, u)u) - \tau(x, u)\varphi^*(u) \\ \quad + \int_{t-\tau(x, u)}^t \psi(v(\tau))d\tau \end{array} \right. \quad (18)$$

involving the initial and Dirichlet conditions.

- **Upper Estimate Set**  $\sigma(t, x, u) := \min(t, \tau(x, u))$ .

$$\mathbf{N}(t, x) \leq \sup_{u \in \text{Dom}(\varphi^*)} \left( \mathbf{c}(t - \sigma(t, x, u), x + \sigma(t, x, u)u) - \left\langle u, \int_{t - \sigma(t, x, u)}^t v(\tau) d\tau \right\rangle \right)$$

- **A posteriori Maximum Principle**

$$\mathbf{N}(t, x) \leq \sup_{t \geq 0, x \in K} \mathbf{c}(t, x) + t \mathbf{Diam}(\text{Dom}(\varphi^*)) \sup_{t \geq 0} \|v(t)\|$$

- **Lower estimate** ( $v(t) =: v$  is constant)

$$\mathbf{c}(t - \sigma(t, x, \psi'(v)), x + \sigma(t, x, \psi'(v))\psi'(v)) + \sigma(t, x, \psi'(v)) \langle v, \psi'(v) \rangle \leq \mathbf{N}(t, x)$$

- **The hyposolution is nonnegative on its positivity domain**  $\text{Dom}_+(\mathbf{N})$ , defined as the subset of pairs  $(t, x) \in \mathbb{R}_+ \times K$  such that

$$\mathbf{c}(t - \sigma(t, x, \psi'(v)), x + \sigma(t, x, \psi'(v))\psi'(v)) + \sigma(t, x, \psi'(v)) \langle v, \psi'(v) \rangle \geq 0$$

We set  $\sigma(t, x, u) := \min(t, \tau(x, u))$ . The viability hyposolution can be written

$$\left\{ \begin{array}{l} \mathbf{N}(t, x) = \sup_{u(\cdot)} \left( \max \left( \mathbf{c} \left( t - \sigma(t, x, u(\cdot)), x + \int_0^{\sigma(t, x, u(\cdot))} u(\tau) d\tau \right) - \int_0^{\sigma(t, x, u(\cdot))} \varphi^*(u(\tau)) d\tau + \int_{t - \sigma(t, x, u(\cdot))}^t \psi(v(\tau)) d\tau, \right. \right. \\ \left. \left. \inf_{s \in [0, \sigma(t, x, u(\cdot))]} \left( \mathbf{b} \left( t - s, x + \int_0^s u(\tau) d\tau \right) - \int_0^s \varphi^*(u(\tau)) d\tau + \int_{t-s}^t \psi(v(\tau)) d\tau \right) \right) \right) \end{array} \right. \quad (19)$$

**Theorem 7** *The viability hypsolution  $\mathbf{N}$  is the largest upper semicontinuous solution between  $c$  and  $b$  satisfying*

$$\psi(v(t)) \geq \inf_{u \in \text{Dom}(\varphi^*)} (\varphi^*(u) - D_{\downarrow} \mathbf{N}(t, x)(-1, u)) \quad (20)$$

*If the functions  $\psi$ ,  $\varphi^*$  and  $v$  are furthermore Lipschitz, then  $\mathbf{N}$  is the smallest upper semicontinuous solution satisfying*

1. *If  $\mathbf{N}(t, x) < b(t, x)$ , then*

$$\psi(v(t)) \leq \inf_{u \in \text{Dom}(\varphi^*)} (D_{\downarrow} \mathbf{N}(t, x)(1, -u) + \varphi^*(u)) \quad (21)$$

2. *If  $\mathbf{N}(t, x) = b(t, x)$ , then*

$$\psi(v(t)) \leq \inf_{\{u \mid \psi(v(t)) \leq D_{\downarrow} b(t, x)(1, -u) + \varphi^*(u)\}} (D_{\downarrow} \mathbf{N}(t, x)(1, -u) + \varphi^*(u)) \quad (22)$$



## *Barron-Jensen/Frankowska Solution : The Hypodifferentiable Case*

If the viability hyposolution is hypodifferentiable (this is the case when it is Lipschitz), then the viability hyposolution is the solution to

$$\forall t > 0, \forall x \in \text{Int}(K) \text{ such that } \mathbf{N}(t, x) < \mathbf{b}(t, x),$$

$$\forall (p_t, p_x) \in \partial_+ \mathbf{N}(t, x), \quad p_t + \psi(p_x) = \psi(v(t))$$

**Theorem 8** *The viability hyposolution  $\mathbf{N}$  is the largest upper semicontinuous solution between  $c$  and  $b$  satisfying*

$$\begin{cases} (i) & \forall t > 0, \forall x \in \text{Int}(K), \forall (p_t, p_x) \in \partial_+ \mathbf{N}(t, x), p_t + \psi(p_x) \leq \psi(v(t)) \\ (ii) & \forall t > 0, \forall x \in \text{Int}(K), \forall (p_t, p_x) \in (\text{Dom}(D_\downarrow \mathbf{N}(t, x)))^-, p_t - \sigma(\text{Dom}(\varphi^*), p_x) \leq 0 \end{cases} \quad (23)$$

If the functions  $\psi$ ,  $\varphi^*$  and  $v$  are furthermore Lipschitz, then  $\mathbf{N}$  is the **smallest upper semi continuous solution between  $\mathbf{c}$  and  $\mathbf{b}$  satisfying**

1. If  $\mathbf{N}(t, x) < \mathbf{b}(t, x)$ , then

$$\left\{ \begin{array}{l} (i) \quad \forall t \geq 0, \forall x \in K \text{ such that } \mathbf{N}(t, x) < \mathbf{b}(t, x), \forall (p_t, p_x) \in \partial_+ \mathbf{N}(t, x), \\ \quad p_t + \psi(p_x) \geq \psi(v(t)) \\ (ii) \quad \forall t \geq 0, \forall x \in K \text{ such that } \mathbf{N}(t, x) < \mathbf{b}(t, x), \forall (p_t, p_x) \in (\text{Dom}(D_\downarrow \mathbf{N}(t, x)))^-, \\ \quad p_t - \sigma(\text{Dom}(\varphi^*), p_x) \geq 0 \end{array} \right. \quad (24)$$

2. If  $\mathbf{N}(t, x) = \mathbf{b}(t, x)$ , then

$$\left\{ \begin{array}{l} \forall (p_t, p_x) \in \partial_+ \mathbf{N}(t, x), \exists (q_t, q_x) \in \partial_+ \mathbf{b}(t, x) \text{ and } 0 < \mu < 1 \text{ such that} \\ \text{either } p_t - q_t - \sigma(\text{Dom}(\varphi^*), p_x - q_x) \geq 0 \\ \text{or } \frac{p_t - \mu q_t}{1 - \mu} + \psi\left(\frac{p_x - \mu q_x}{1 - \mu}\right) \geq \psi(v(t)) \end{array} \right. \quad (25)$$



Thanks for your attention  
Merci pour votre attention

